

H

Y

P

D

N

USER MANUAL V1.00

HP51100

HBP-LV Battery System



CONTENT



1. INTRODUCTION	3
1.1 Safety And Warnings.....	3
1.2 Label Description	4
1.3 Emergency Measures	5
2. Product Introduction	6
2.1 Dimension	6
2.2 Technical Data.....	6
2.3 Interface	7
3. Storage and Installation	8
3.1 Storage Environment.....	8
3.2 Installation Environment.....	8
3.3 Installation Clearance Requirements	10
3.4 Installation Angle Requirements	11
3.5 Safety Gear.....	11
3.6 Unpacking inspection	12
3.7 Equipment installation	15
3.8 Cable Connection of Single Battery System	20
3.9 Commissioning for Single Battery System	23
3.10 Battery Model Setting.....	25
3.11 Shutdown for Single Battery System	26
3.12 Cable Connection of Parallelized Battery System.....	27
3.13 Commissioning for Parallelized Battery System.....	30
3.14 Battery Model Setting for Parallelized Battery System	32
3.15 Shutdown for Parallelized Battery System	32
3.16 Indicator Status	33
4. Maintenance	35
4.1 Trouble Shooting.....	35
4.2 Battery Maintenance.....	36
5. Transportation	37
6. Disclaimer	38

1. INTRODUCTION

1.1 Safety And Warnings

1. Dangerous DC voltages in the battery could cause lethal electrical shocks. All persons who are responsible for mounting, installation, commissioning, maintenance, tests, and service of the battery products must be suitably trained and qualified for corresponding operations. They MUST be experienced and have knowledge of operation safety and professional methods. All installation personnel must have knowledge of all applicable safety information, standards, directives, and regulations.
2. Do not hit, pull, drag, squeeze or step on the equipment or put the battery into fire. Otherwise, the battery may explode.
3. Do not disassemble, modify, or replace any part of the battery or the power control unit without official authorization from the manufacturer. Otherwise, it will cause electrical shock or damages to the equipment, which shall not be borne by the manufacturer.
4. Do not place the battery in a high temperature environment. Make sure that there is no direct sunlight and no heat source near the battery. When the ambient temperature exceeds 60 °C, it will cause fire.
5. The battery should be tied or fixed during transportation. The battery should be protected from heavy vibrations and shocks during transportation. The transport of the battery requires two people for lifting, there is one handle on the left and one on the right.
6. Do not use the battery or the power control unit if it is defective, broken, or damaged. The damaged battery may leak electrolytes.
7. Contact after-sale service immediately if the battery is not able to be started. Otherwise, the battery might be damaged permanently.
8. Do not move the battery system if it is connected to external battery modules. Contact after-sales service if the battery shall be replaced or added.

1.2 Label Description

	DANGER, WARNING AND CAUTION
	HIGH VOLTAGE AVOID CONTACT
	USER MANUAL IN PACK
	BATTERIES CONTAIN FLAMMABLE MATERIALS, BEWARE OF FIRE
	DO NOT DISPOSE WITH HOUSEHOLD WASTE
	INSTALL THE EQUIPMENT AWAY FROM FIRE SOURCES
	KEEP THE EQUIPMENT AWAY FROM CHILDREN.
	CE MARKS
	TUV MARKS
	RECYCLABLE AND REUSABLE

1.3 Emergency Measures

Battery Electrolyte Leakage

If the battery module leaks electrolyte, avoid contact with the leaking liquid or gas. The electrolyte is corrosive. It will cause skin irritation or chemical burns to the operator.

Anyone contacting the leaked substance accidentally has to do the following:

- **Breath in the leaked substance:** Evacuate from the polluted area, and seek immediate medical assistance.
- **Eye contact:** Rinse your eyes for at least 15 minutes with clean water and seek immediate medical assistance.
- **Skin contact:** Thoroughly wash the touch area with soap and clean water, and seek immediate medical assistance.
- **Ingestion:** Induce vomiting, and seek immediate medical assistance.

Fire

- The battery may explode when the ambient temperature exceeds 150°C. Poisonous and hazard gas may be released if the battery is on fire.
- In the event of a fire, please make sure that the carbon dioxide extinguisher or Novac1230 or FM-200 is nearby.
- The fire cannot be put out by water or ABC dry powder extinguisher. Firefighters are required to wear full protective clothing and self-contained breathing apparatus.

2. Product Introduction

2.1 Dimension

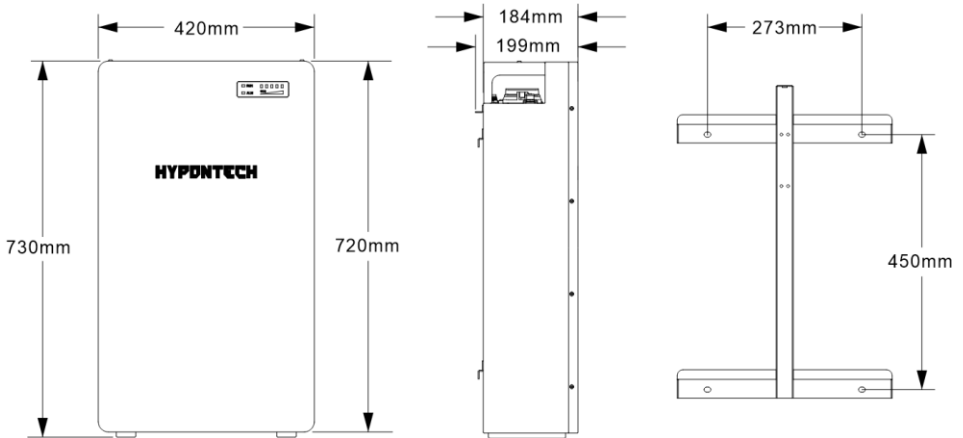

2.2 Technical Data

Key item	Specification
Cell Type	LFP(LiFePO ₄)
Nominal Voltage	51.2Vdc
Nominal Capacity	100Ah
Nominal Energy	5.12kWh
Max. Parallel Quantity	Max.10 sets in parallel, 51.2kWh
Operating Voltage Range	42.4V~56V
Recommend Charging/Discharging Current	50A
Max. Continuous charging current	80A
Max. Continuous discharging current	100A
IP Class	IP65
Ambient Temperature Range	-20-60°C
Operation Humidity	5-95% (Non-Condensing)
Altitude	3000m
Communication Port	CAN
Weight	55kg
Designed Cycle Life	8000 cycles @ 95% DOD / 25°C / 1C / 70% SOH

2.3 Interface

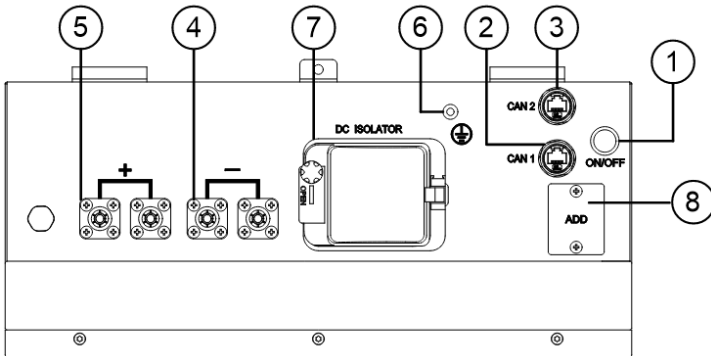

No.	Part	Notes
1	Power Button	Turn on/off battery system
2	CAN1 Port	In parallelized battery system, CAN 1 Port on the Master unit must be connected with inverter.
3	CAN2 Port	In parallelized battery system, CAN 2 Port must be connected with CAN 1 Port of next battery system.
4	Port Negative x2	Black, matched cable 25mm ²
5	Port Positive x2	Red, matched cable 25mm ²
6	GND	M5 screw, Yellow-Green cable, 10 AWG
7	DC Isolator	125A, with waterproof cover
8	ADD Switch	Under the metal lid: 4-bit DIP switch

3. Storage and Installation

3.1 Storage Environment

If the equipment is not to be installed or used immediately, please ensure that the storage environment meets the following requirements:

1. Do not unpack the outer packing box or throw the desiccant away.
2. Complete the equipment installation in three days after unpacking it. Pack and store the equipment using the original packing box if it is not installed.
3. Stack the equipment complying with the labels and requirements on the packing box.
4. The equipment must be stacked with caution to prevent them from falling.
5. Keep the equipment away from flammable, explosive, and corrosive matters.
6. Place the equipment in a cool place away from direct sunlight.
7. Store the equipment in a clean place. Make sure the temperature and humidity are appropriate and no condensation.
8. Storage SOC: 20%~50% SOC. Circle the charge-discharge every 3 months to maintain SOC between 20% and 50%, to ensure no over-discharge of battery occurs.
9. Recommended storage temperature: -20~35°C
10. Recommended storage humidity: 0%~80%RH (no condensation). Do not install the battery if there is any moisture or condensation.
11. Keep the equipment away from the rain.

3.2 Installation Environment

1. A solid and flat support surface must be available (e.g. concrete or masonry).
2. The installation location must be suitable for weight and dimensions of the system.
3. The installation location must be inaccessible to children.
4. The installation location must not be exposed to direct sunlight or rain.
5. The installation location must not be close to fire, inflammable or explosive matters.
6. The installation location must not be close to heat/cold source.
7. The installation location must not be a place prone to accumulate water
8. The installation location must not be a place where temperature changes extremely.
9. The installation location must be a place away from strong interferences.

10. The installation location must be away from conductive (metal) dust.
11. The altitude of the installation location shall be less than 3000m.
12. The ambient temperature shall be between -20°C and +60°C.
13. The ambient humidity should be between 5-95%.

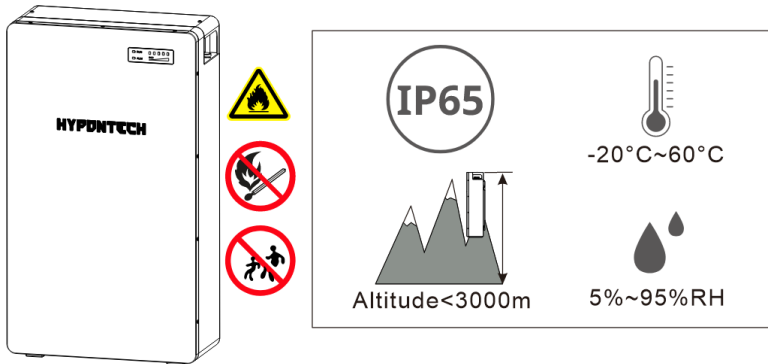
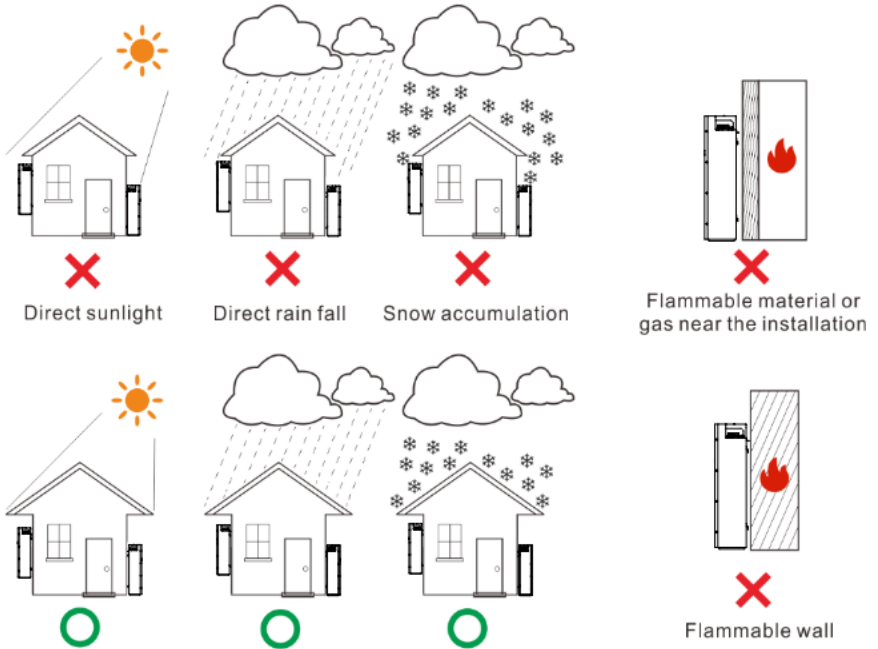

3.3 Installation Clearance Requirements

Please note that the battery should be installed with a proper and safe clearance from the surrounding equipment or battery. Please refer to the minimum clearance diagram below:

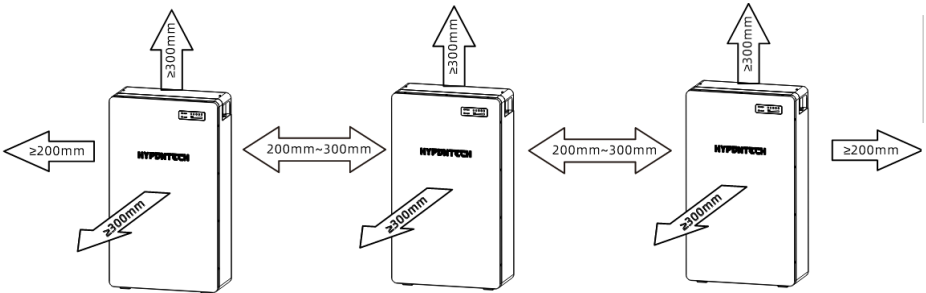

The installation distance shall satisfy the requirements of the battery and the inverter at the same time when an inverter is connected with the battery system.

For the installation distance requirement of the inverter, please refer to **User Manual** of Hypon HES series inverter.

3.4 Installation Angle Requirements

Install the equipment vertically, no tilt or upside down.

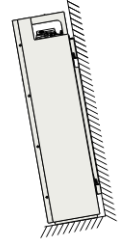
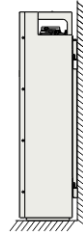
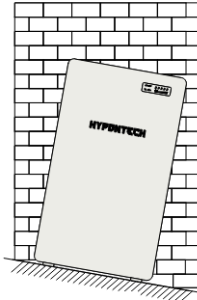
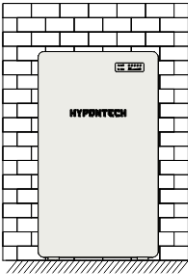
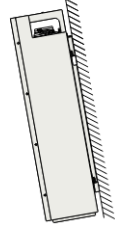
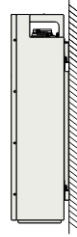
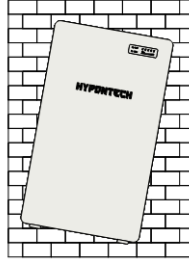
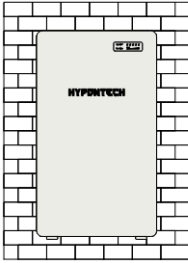

3.5 Safety Gear

It is recommended to wear the following safety gear when dealing with the battery pack.



Insulated gloves



Safety goggles





Safety shoes

3.6 Unpacking inspection



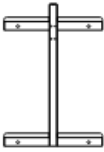

Check the following items before receiving the product.

1. Check the outer packing box for damage, such as holes, cracks, deformation, and other signs of equipment damage. Do not unpack the package and contact the supplier as soon as possible if any damage is found.
2. Check the product model. If the product model is not what you requested, do not unpack the product and contact the supplier.
3. Check the deliverables for correct model, complete contents, and intact appearance. Contact the supplier as soon as possible if any damage is found.



3.6.1 Packing List (Single Unit)

Item	Quantity	Figure
Battery System	1	
Mounting plate	1	
Mounting Accessories	1	
Documents	1	





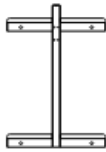



Configured Parts in Single Unit

Item	Qty	Figure	Detail
Output Power Cable (+)	1		1.5m
Output Power Cable (-)	1		1.5m
Grounding Cable	1		1.5m
Output Communication Cable	1		1.5m
Waterproof module	1		

3.6.2 Part List (N-unit in Parallelized Battery System)

Item	Quantity	Figure
Battery System	N	
Mounting plate	N	
Mounting Accessories	N	
Documents	N	

The following accessories are configured depending on the number of units in parallelized battery system:

Item	Qty	Figure	Detail
Output Power Cable (+)	1		1.5m
Output Power Cable (-)	1		It can be optional ^[1]
Grounding Cable	1		1.5m
Output Communication Cable	1		1.5m
Parallel Power Cable (+)	N-1		0.8m
Parallel Power Cable (-)	N-1		0.8m
Parallel Grounding Cable	N-1		0.8m
Parallel Communication Cable	N-1		0.8m
Waterproof module	2N-1		

N=Number of units in parallelized battery system ($2 \leq N \leq 10$)

[1] Output Power Cable (-) can be optional according to the actual installation requirements:

1.5m: For single battery.

3.2m: For 2-3 units in parallel.

5.5m: For 4-6 units in parallel.

For longer cable, please contact Hypon.

3.7 Equipment installation

3.7.1 Installation Preparation

Operations such as transportation, turnover, installation, and so on must meet the requirements of the laws and regulations of the country or region where it is located.

1. The battery module is 55kg. It's necessary to arrange more than 1 person to install the battery module if without lifting equipment, more than 2 persons when installing battery module in higher position.
2. Keep balance to avoid falling down when moving the equipment.
3. Confirm that the DC isolator is in the OFF state to ensure that there is no live operation.

3.7.2 Floor Mounting

Step 1: Mark locating points

Place the mounting plate close to the wall and floor firmly;

Mark the 2 locating points to wall with hole on the mounting plate as shown below:

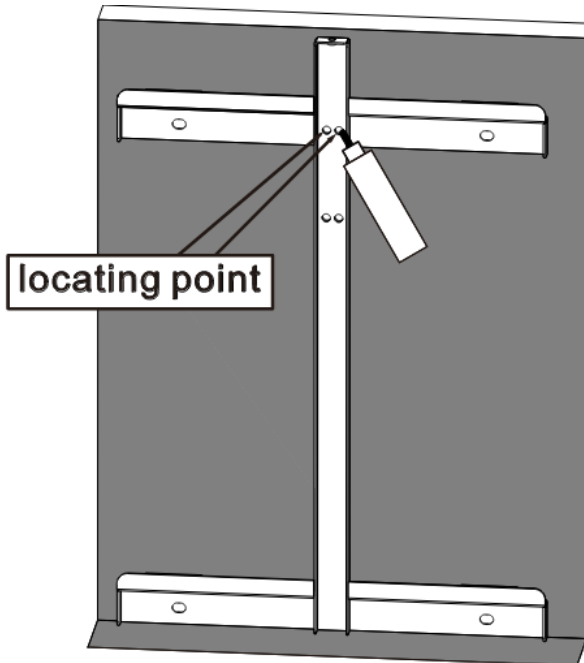

Step 2: Mark fixed position

Lift up the mounting plate and align the other 2 holes with the 2 location points marked on the wall in step 1;

Mark the 4 fixed position with the mounting plate.

Measuring distance from floor to bottom of the mounting plate can also ensure the height (76~80mm).

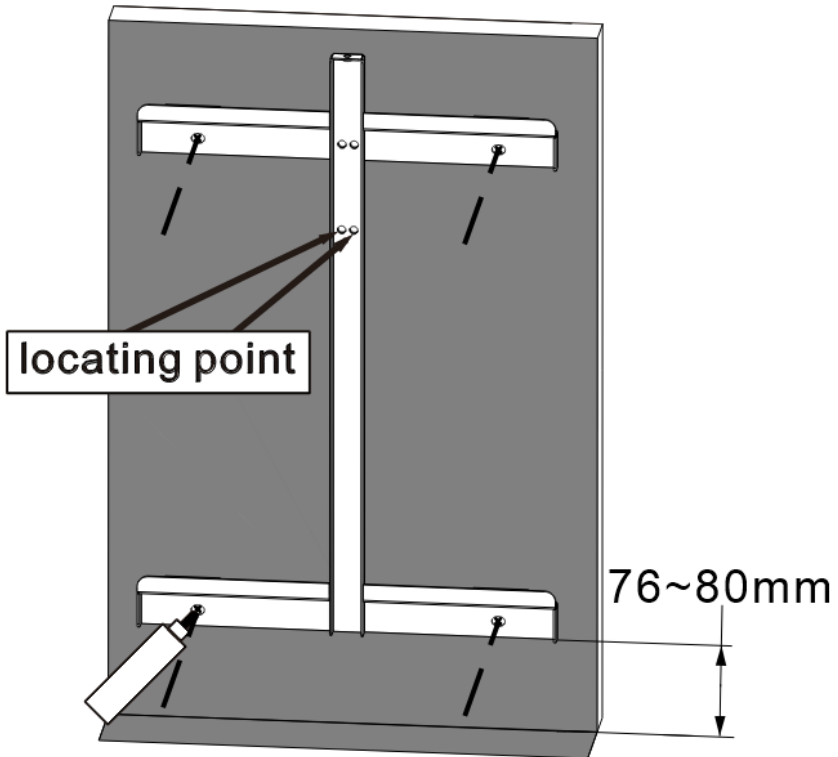

Step 3: Drill holes

Drill 4 holes on the wall using an impact electric driller.

Hole diameter: 12mm

Hole depth:70mm

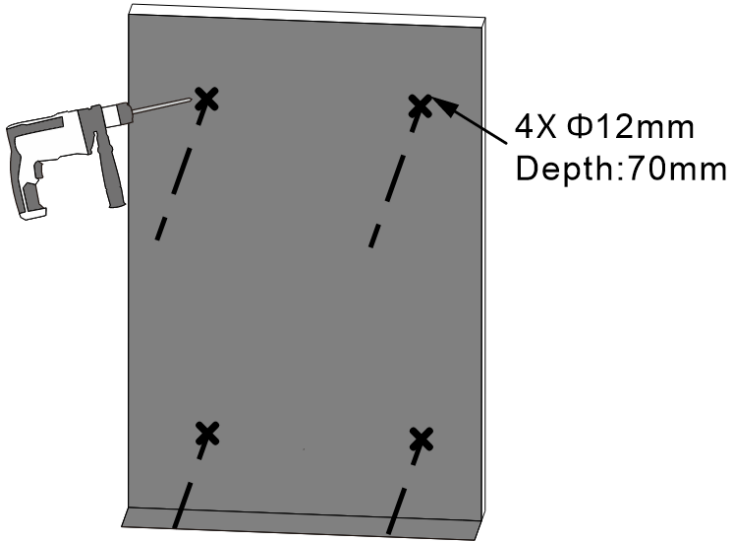

Step 4: Install mounting plate

Fix the mounting plate with the expansion screw packed in mounting accessories.

Tightening Torque: 12N·m

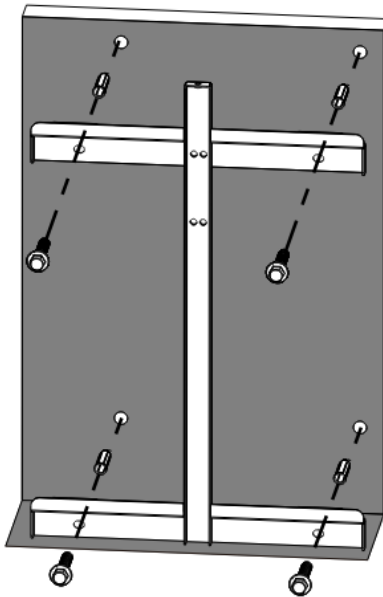

Step 5: Hang the battery system

Firstly, remove the cover from the battery system ((Use T20 screwdriver);
Hang the battery system on the mounting plate.

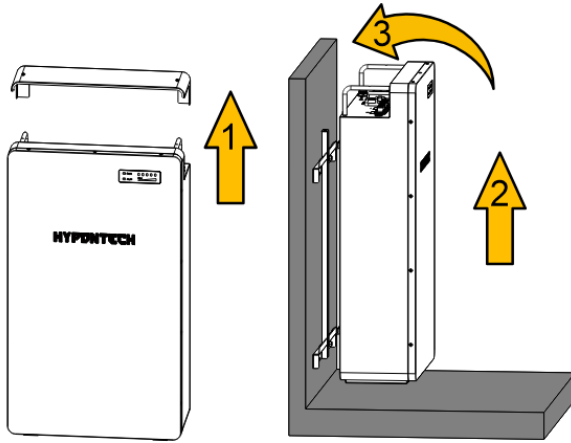

Step 6: Fix the battery system

Use M5 bolt (Use T25 screwdriver) in mounting accessories to fix the battery system
for keeping horizontal.

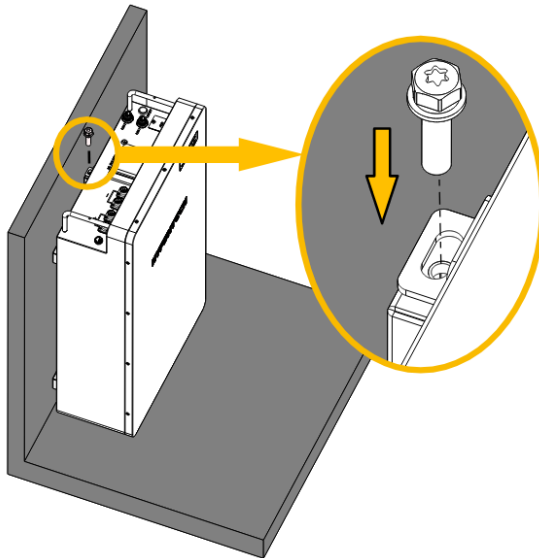

3.7.3 Wall Mounting

Step 1: Mark fixed position

Lift up the mounting plate to enough height ($\geq 80\text{mm}$).

Place the mounting plate close to the wall firmly and keep horizontal;

Mark the 4 fixed position with the mounting plate.

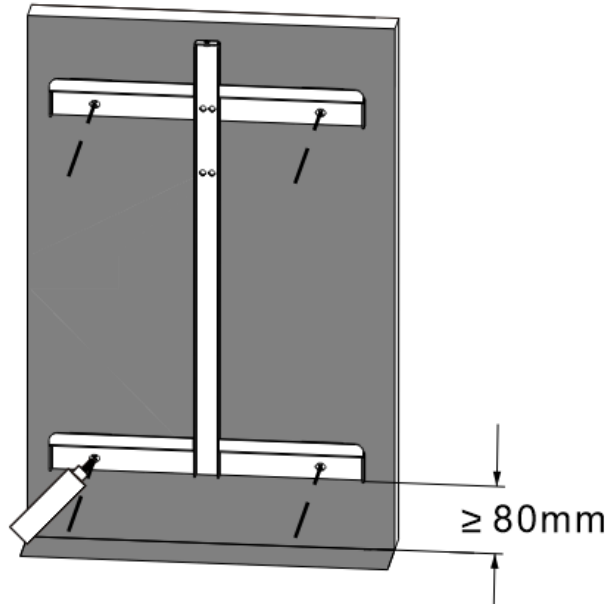

Repeat **Step3~Step6** in **section 3.7.2 Floor Mounting**

Notice: Ensure the battery system and mounting bracket have been installed correctly and tightly.

3.8 Cable Connection of Single Battery System

3.8.1 Overview of the Cable Connection

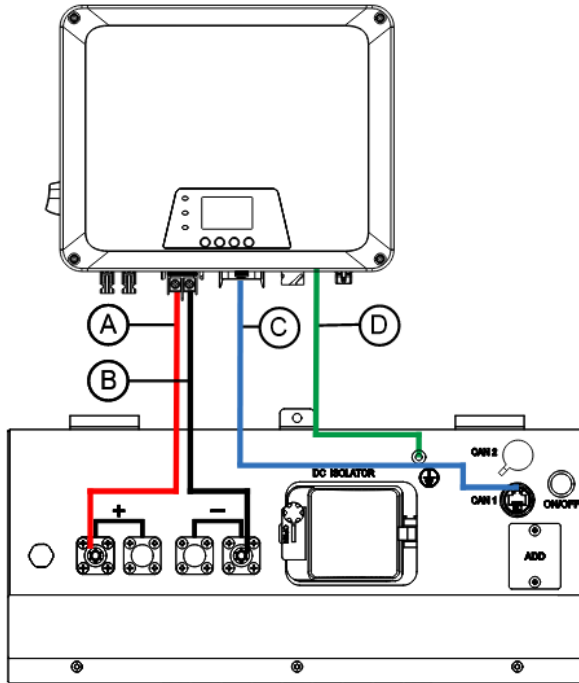

A: Power Cable + (Red);

B: Power Cable - (Black)

C: Communication cable;

D: Grounding Cable (Connect to inverter)

3.8.2 Ground Connection

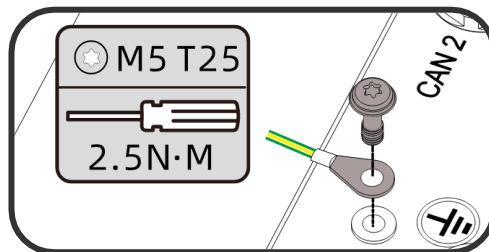

Connect the PE cable first before installing the equipment.

Disconnect the PE cable last when dismantling the equipment.

3.8.3 Power Cable Connection

Meeting the following requirements is mandatory. All warranty rights will otherwise be invalid:

1. The DC breaker between the inverter and the battery, and between the two batteries, shall be installed in accordance with local laws and regulations. The breaker should isolate both positive and negative conductors simultaneously.
2. Prevent reverse polarity connection!
3. If the Battery connectors are not assembled properly and locked into place, arc or overheat may be induced.

Plug the power connectors into power port. If hearing sound “Click”, the connectors are installed properly.

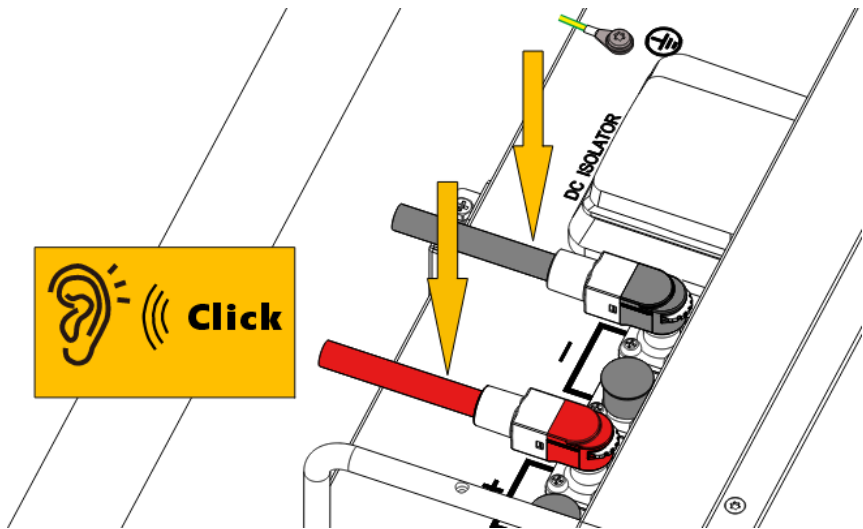

Notice: If there is an unused terminal, please seal it with protective cap.

3.8.5 Connect Cables to Inverter

The battery system is only compatible with Hypon HES series inverter.

Connect cables (power cables, grounding cable, communication cable) to inverter as shown in **section 3.8.1**.

For specific installation methods of connecting cable with inverter, please see the HES series inverter manual.

3.9 Commissioning for Single Battery System

3.9.1 Inspection before Commissioning

Please check if

1. The battery system and mounting bracket have been correctly installed.
2. The battery system's exposed metal surface has a ground connection.
3. Double check all the power cables and communication connectors have been correctly wired and tightened.
4. For any unused terminals, please seal them with protective caps.
5. Make sure the voltage of the inverter is in the same level with the battery system.
6. The installing on place is clean and well ventilated.
7. The place is convenient for operation on and maintenance.

3.9.2 Startup Battery System

1. Switch on the inverter, to make sure all the power equipment can work normally.
2. Startup the battery system:

Step 1: Turn on the DC isolator in the battery system;

Press Power button to turn on the battery system. After 1 seconds:

- a. If green LED (RUN) on battery is on and red LED (ALM) is off, it indicates normal operation. Proceed to step 2.
- b. If the LED shows other states, it indicates that an alarm have occurred. Please stop the commissioning procedure and shut down (**section 3.11**) the battery immediately. Read **section 3.16** to seek for solution.

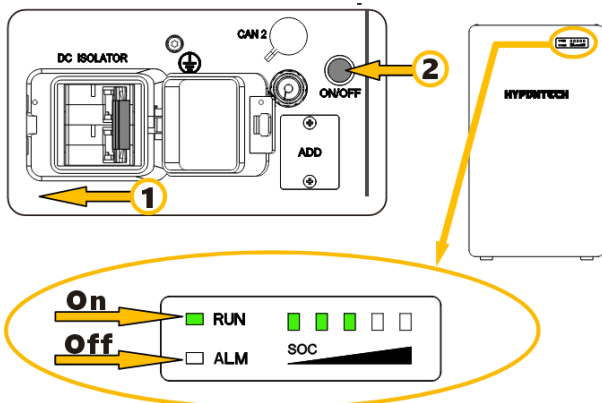

Image Step 1

Step 2: Tighten the screw on cover of DC isolator.

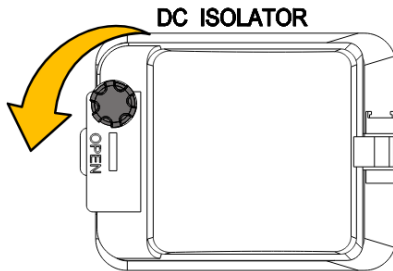

Image Step 2

Step 3: Close the top cover after the battery system is turned on.
(Use T20 screwdriver).

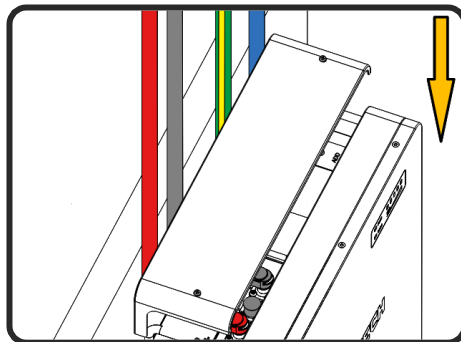

Image Step 3

3.10 Battery Model Setting

3.10.1 Scan the QR code to download the HYPON.Cloud APP



Google Play

APP Store

Android Apk

3.10.2 Select the battery model

Select the right battery model in **Parameter Settings of Inverter** on Hypon.Cloud:

“*Hypontech-LV*”.

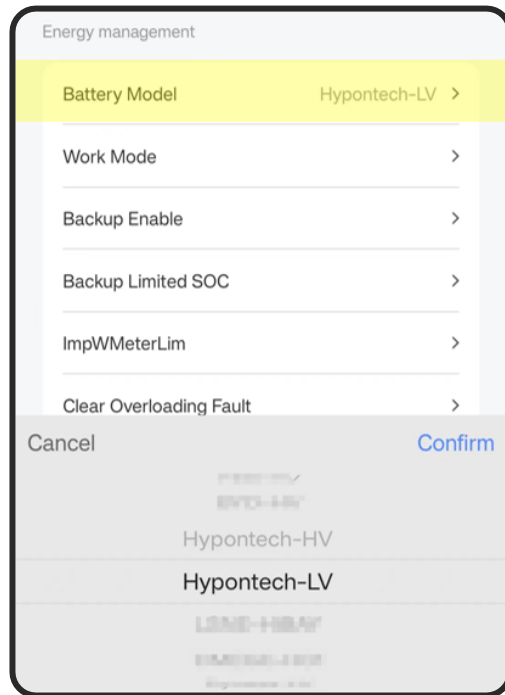

3.11 Shutdown for Single Battery System

Step 1: Press the Power button from side for at least 3 seconds until the indicator lights are off.

Step 2: Remove the top cover from the battery system (Use T20 screwdriver).

Step 3: Turn off the DC isolator in the battery system.

Step 4: Make sure that indicator is off.

Step 5: Tighten the screw on cover of DC isolator.

Step 6: Close the top cover after the battery system is shutdown.
(Use T20 screwdriver).

3.12 Cable Connection of Parallelized Battery System

3.12.1 Overview of the Cable Connection

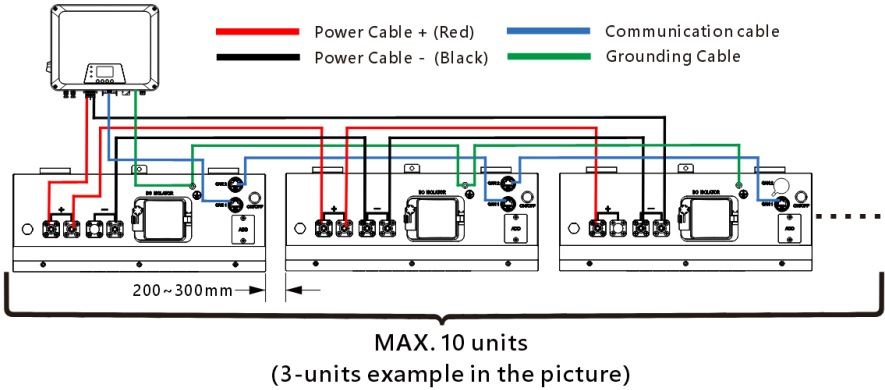

Notice: If multi batteries are to be connected, check and select batteries with similar production date and a same cell grade.

3.12.2 Ground Connection

Please refer to **section 3.8.2**.

The middle unit in parallelized battery system needs to install two terminal lugs.

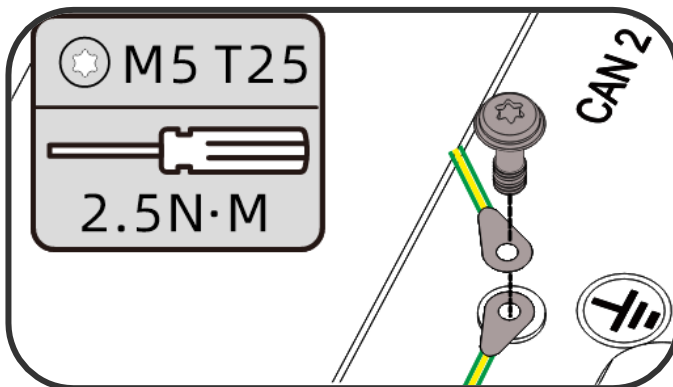

3.12.3 Power Cable Connection

Please refer to **section 3.8.3**.

Connect power cables between multi batteries in parallel, which means connect positive pole of one battery to the positive pole of the next battery, and negative pole to negative pole.

Notice: Cover and protect the reserved power port of the first and last battery.

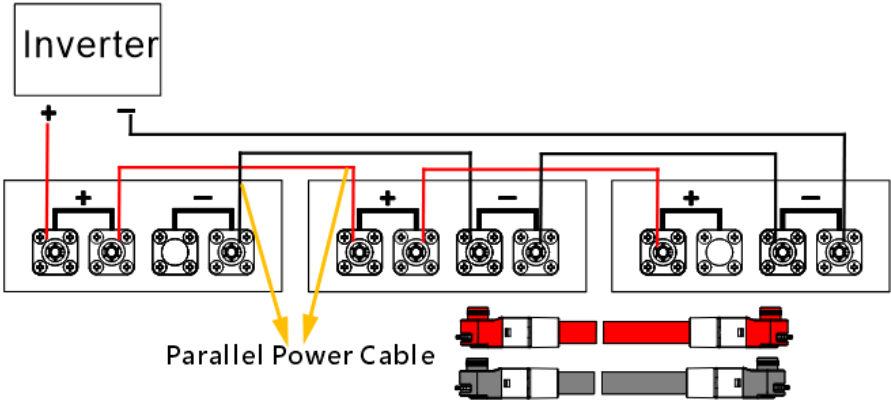

3.12.4 Communication Cable Connection

Please refer to **section 3.8.4**.

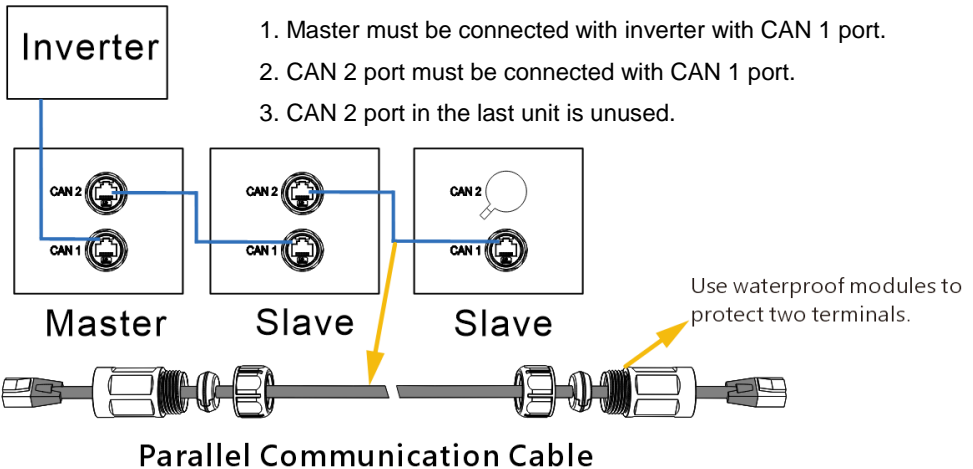

3.12.5 Parallel Communication Address for Parallel Battery Systems

ADD switch is a 4-bit DIP switch to manually distribute the communication address of parallel batteries.

The BMS will only recognize the DIP address once it is reset, so please reset the BMS when the DIP address is changed (Battery system must be reset in shutdown state).

Step 1: Remove “ADD” lid (Use T20 screwdriver).

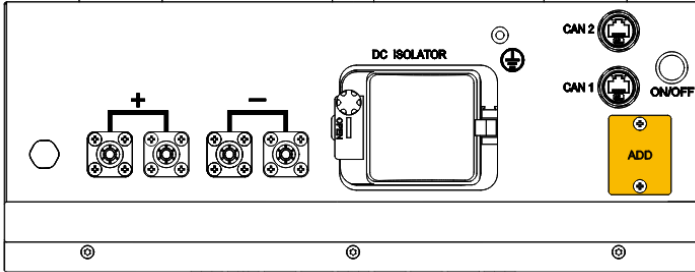

Step 2: Set DIP switch as required shown in *image 3.12.5-1* & *image 3.12.5-2*:

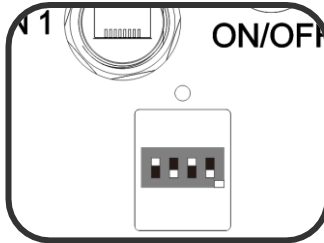

The battery is configured as the stand-alone working mode & master working mode when the DIP address is shown as below (**Factory Default Setting**):



image 3.12.5-1

The battery is configured as the slave working mode when the DIP address is shown as below:

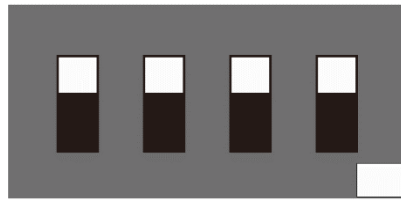
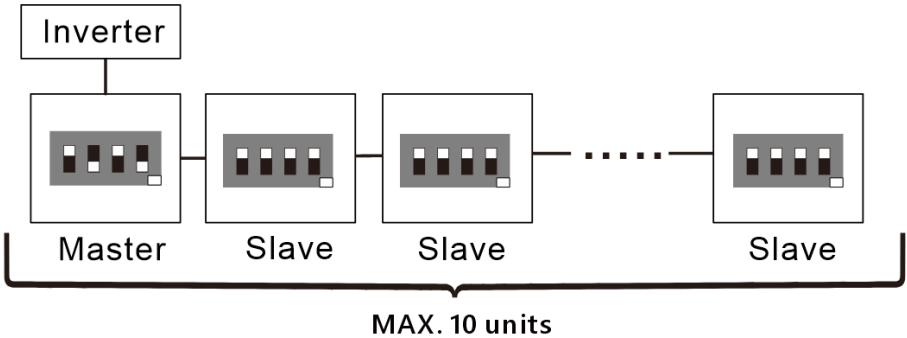

image 3.12.5-2

Correct state of ADD switch in parallel battery system



3.12.6 Connect Cables to Inverter

The parallelized battery system is only compatible with Hypon HES series inverter.

Connect cables (power cables, grounding cable, communication cable) to inverter as shown in **section 3.12.1**.

For specific installation methods of connecting cable with inverter, please see the HES series inverter manual.

3.13 Commissioning for Parallelized Battery System

3.13.1 Inspection before commissioning

Please check if

1. The battery system and mounting bracket have been correctly installed.
2. The battery system's exposed metal surface has a ground connection.
3. Double check all the power cables and communication connectors have been correctly wired and tightened.
4. For any unused terminals, please seal them with protective caps.
5. Make sure the voltage of the inverter is in the same level with the battery system.
6. The installing on place is clean and well ventilated.
7. The place is convenient for operation on and maintenance.

3.13.2 Startup Battery System

1. Switch on the inverter, to make sure all the power equipment can work normally.
2. Startup the battery system:

Step 1: Turn on **all*** DC isolators in the parallelized battery system;

Press Power button of **Master unit** to turn on all batteries. After 1 seconds:

a. If **all*** green LEDs (RUN) in the parallelized battery system are on and **all*** red LEDs (ALM) are off, it indicates **all*** batteries are operating normally.

Proceed to step 2.

b. If **any*** LED in the parallelized battery system shows other states, it indicates that an alarm has occurred. Please stop the commissioning procedure and shut down (**section 3.15**) parallelized battery system immediately. Read **section 3.16** to seek for solution.

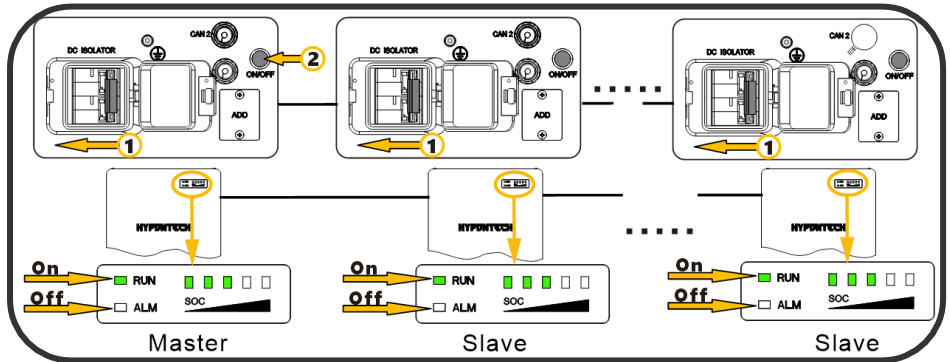

Image Step 1

Step 2: Tighten **all*** screws on cover of DC isolators.

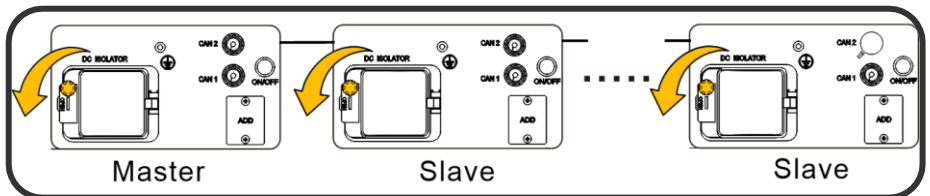

Image Step 2

Step 3: Close **all*** top covers after the battery system is turned on.
(Use T20 screwdriver).

*: including Master Unit & Slave Units

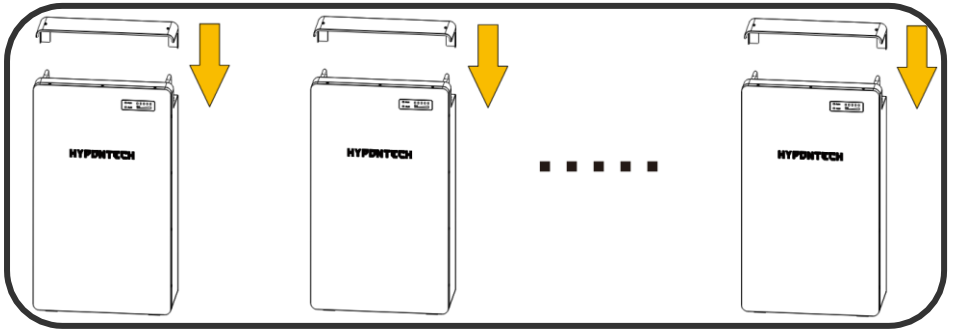

Image Step 3

3.14 Battery Model Setting for Parallelized Battery System

Please follow the same step in **section 3.10**

3.15 Shutdown for Parallelized Battery System

Step 1: Press the Power button of **Master Unit** for at least 3 seconds until **all*** indicator lights are off.

Step 2: Remove **all*** top covers from the battery systems (Use T20 screwdriver).

Step 3: Turn off **all*** DC isolators in the parallelized battery system.

Step 4: Make sure that **all*** indicators are off.

Step 5: Tighten **all*** screws on cover of DC isolators.

Step 6: Close **all*** top cover after the parallelized battery system is shutdown.
(Use T20 screwdriver).

*: including Master Unit & Slave Units

3.16 Indicator Status

Capacity indication

State Indicator	SOC Indicator	Description
$0% < \text{SOC} < 20\%$		SOC1 is steady green or flash
$20\% \leq \text{SOC} < 40\%$		SOC1, SOC2 are steady green or flash
$40\% \leq \text{SOC} < 60\%$		SOC1, SOC2, SOC3 are steady green or flash
$60\% \leq \text{SOC} < 80\%$		SOC1, SOC2, SOC3, SOC4 are steady green or flash
$80\% \leq \text{SOC} \leq 100\%$		SOC1, SOC2, SOC3, SOC4, SOC5 are steady green or flash



Normal State

States	RUN	ALM	SOC1	SOC2	SOC3	SOC4	SOC5
Shutdown	Off	Off	Off	Off	Off	Off	Off
Standby	Flash	Off	Shown based on capacity.				
Discharge	On	Off	Shown based on capacity. The highest level of SOC Indicator flashes (refer to Capacity indication) to indicate the battery is charging/ discharging.				
Charge	Flash	Off					

Abnormal State

If the following conditions occur, please read **section 4.1** for solutions.



If issues are not resolved, please contact HYPONTECH.

LED Display	Description	System state
	<p>RUN - flash 1 time/s. ALM - steady red. SOC - based on Capacity.</p>	Protection State
	<p>RUN - flash 1 time/s. ALM - flash 4 time/s. SOC - based on Capacity.</p>	MOS Fault

If the following conditions occur, please wait for 20 mins.

If LED don't return to normal state after 20 mins, please check wire connection firstly.

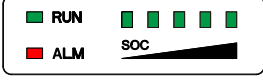
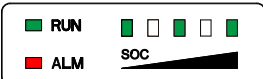
If issues still are not resolved, please contact HYPONTECH.

LED Display	Description	System state
	<p>RUN - steady green. ALM - steady red. SOC - all steady green.</p>	Program Error
	<p>RUN - steady green. ALM - steady red. SOC - Shown as left picture.</p>	Loading Mode
	<p>RUN - off. ALM - off. SOC - Shown as left picture.</p>	CAN Busoff

4. Maintenance

4.1 Trouble Shooting

Danger: The battery system has dangerous DC voltage, operated by professional and authorized person only.

Before check the failure, must check all the cables connection, switches are right or not, and if the battery system can be woken up normally.

No	Problem	Possible Reason	Solution
1	The battery has no voltage output, "RUN" LED and "ALARM" LED are both off.	The DC isolator of the battery system didn't be turned on	Turn on the DC isolator.
		The Power button of the battery system was not switched on.	Switch on the "ON/OFF" power Button.
		Battery is in sleep state.	Switch on the "ON/OFF" power Button.
		Battery voltage is too low to support BMS operation.	Precharge the battery to relieve the protection state
2	The battery has no voltage output, the "ALARM" LED is on.	The MOS in BMS is faulty	Replace a new BMS.
		The battery has triggered a protection	Check connection and battery information
		The battery has triggered a system lock	Contact HYPONTECH
3	When the battery is connected to the inverter, the DC isolator trips automatically	The circuit between the battery and the inverter has a huge short current.	Check whether there is a short circuit in the circuit between the battery and the inverter
		Unusually high temperatures near the battery	Ensure that the battery operates within the specified ambient temperature range
4	Communication failure between battery and inverter.	The wrong battery model type is selected on the inverter on Hypon.Cloud APP.	Select correct battery model type on the inverter on Hypon.Cloud.
		The ADD switch setting is error.	Turn off the battery and set the ADD switch correctly

4.2 Battery Maintenance

Danger: The maintenance of battery only can be operated by professional and authorized person. You need turn off the battery system firstly when you do some maintenance things.

No	Maintaining Item	Maintaining Period
1	Check whether the mounting bracket are secured, tighten it if not.	Once every 6 months
2	Check whether the outer enclosure is broken. Repair the painting or contact after-sales service if there is any broken.	Once every 6 months
3	Check whether there is an exposed cable. Replace the exposed cable or contact the after-sales service for help.	Once every 6 months
4	Check whether there is any dust around the battery module. Clean the dust if there is any to avoid affecting heat dissipation.	Once every 6 months
5	Check whether there is any liquid or pest near the battery to avoid intrusion in a long term.	Once every 6 months
6	Check the voltage of battery system through the monitor software. Check whether the system voltage is normal or not. For example, Check Single cell's voltage is out of rated range or not.	Once every 6 months
7	Check the SOC of battery system through the monitor software. Check the SOC of battery string is normal or not.	Once every 6 months
8	The battery system will become unbalanced if have not be charged fully for a long time. Solution: Preform the balancing maintenance (fully charged) every 3 month. Generally, this maintenance progress needs to be completed when external devices such as the monitor software and battery and inverter are in good communication.	Once every 3 months

5. Transportation

Battery module will pre-charged to 40% SOC or according to customer requirement before shipment. The remaining capacity of battery cell is determined by the storage time and condition after shipment.

- The battery modules meet the UN38.3 certificate standard.
- In particular, special rules for the carriage of goods on the road and the current dangerous goods law, specifically ADR(European Convention on the International Carriage of Dangerous Goods by Road), as amended, must be observed.

6. Disclaimer

The battery protects this product under warranty when it is installed and used as listed in this manual. Violation of the installation procedure or use of the product in any way not described in this manual will immediately void all warranties on the product.

The battery does not provide warranty coverage or assume any liability for direct or indirect damages or defects that result from the following causes:

- Force majeure (flooding, lightning strike, overvoltage, fire, thunderstorm, flooding etc.)
- Improper or noncompliant use
- Improper installation, commissioning, start up or operation (contrary to the guidance detailed in the installation manual supplied with each product)
- Inadequate ventilation and circulation resulting in minimized cooling and natural air flow
- Installation in a corrosive environment
- Damage during transportation
- Unauthorized repair attempts
- Failure to adequately maintain the equipment. An on-site inspection by a qualified technician is possible following 120 months of continuous use. Warranty claims made beyond 120 months from date of commissioning may be declined if it cannot be demonstrated that the equipment has been adequately maintained
- External influence including unusual physical or electrical stress (power failure surges, inrush current, etc.)
- Use of an incompatible inverter or devices
- Connect to other brands inverters without authority from the battery

HYPONTECH

 **HYPON.COM**
@ HYPONTECH SOLAR ENERGIZING FUTURE

SUZHOU HYPONTECH CO., LTD. - HQ OFFICES

SUZHOU HEFENG SCIENCE AND TECHNOLOGY
INNOVATION PARK

NO.2, TAISHAN ROAD, SUZHOU CHINA – 215129

T +86 512 807 12199

E INFO@HYPON.COM

W WWW.HYPON.COM

SUZHOU HYPONTECH CO., LTD. -MANUFACTURING

NO.588 WUTAISHAN ROAD, SND, SUZHOU 215000, CHINA

HYPONTECH DEUTSCHLAND GMBH – GERMANY BRANCH

RUDOLF DIESEL STR. 11, 69115 HEIDELBERGW

E SERVICE@HYPON.COM

BRAZIL OFFICE - SÃO PAULO

JOSÉ ROCHA BOMFIM AVENUE, 214 BLOC B

LONDRES, ROOM 217, CAMPINAS, SÃO PAULO - CEP

13080-650

E SERVICE@HYPON.COM