

DTSU666 series three phase four wire electronic energy meter (Din-rail)

DSSU666 series three phase three wire electronic energy meter (Din-rail)

Manual

ZTY0.464.1002

Zhejiang Chint Instrument & Meter Co., Ltd.

August, 2019.

Catalog

1. Brief Introduction	1
2. Working Principle.....	2
3. Main Technical Performance & Parameters	3
4. Main function.....	6
5. Outline and installation size.....	13
6. Installation and operation manual.....	14
7. Diagnosis, analysis and elimination for common faults	17
8. Transportation & Storage.....	18
9. Maintenance & Service.....	18

DTSU666 series and DSSU666 series three phase electronic energy meter(DIN-Rail)	ZTY0.464.1002
Operation manual	Page 2, Total 18

- 2) RS485 communication interface, easy to exchange data with outside;
- 3) Adopting the standard DIN35mm din rail mounting and modular design, it is characterized with small volume, easy installation and easy networking.

1.3. Product Model

Table 1 product model and specification

Model	voltage (V)	Current (A)	Impulse constant		Accuracy class
			imp/kWh	imp/kvarh	
DTSU666	3×230/400	1.5(6)A	6400	6400	Active Class 0.5S, Reactive Class 2
		5(80)A	400	400	Active Class 1, Reactive Class 2
DSSU666	3×400	1.5(6)A	6400	6400	Active Class 0.5S, Reactive Class 2
		5(80)A	400	400	Active Class 1, Reactive Class 2

Note: 1.5(6)A is Connection through current transformers, 5(80)A is direct access.

1.4. Temperature range

Regulated working temperature range: $-10^{\circ}\text{C} \sim +45^{\circ}\text{C}$;

Limited working temperature range: $-25^{\circ}\text{C} \sim +75^{\circ}\text{C}$;

Relative humidity(Annually average): $\leq 75\%$;

Atmospheric pressure: 63.0kPa \sim 106.0kPa(altitude 4km and below), excepting the requirements for special orders.

2. Working Principle

2.1. Working Principle

The instrument are composed of high accurately integrated circuit specially for measurement (ASIC) and managing MCU, memory chip, RS485 communication module, etc.

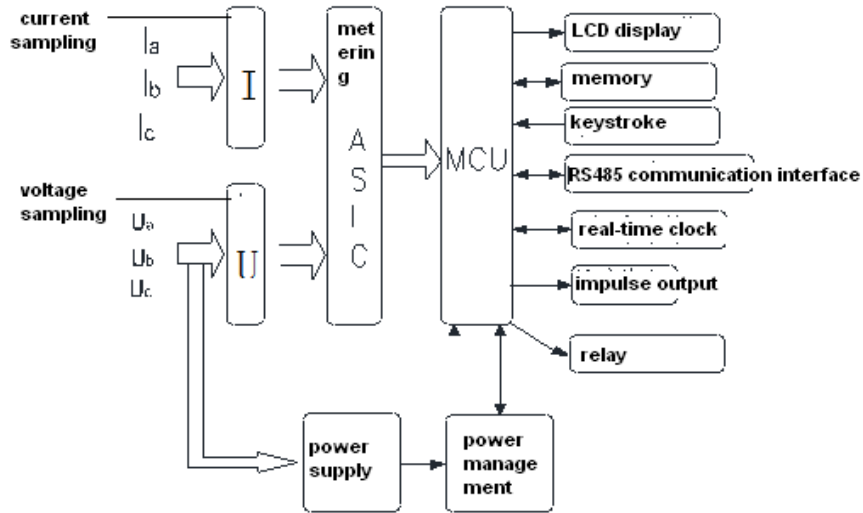

Figure 1 Working principle block diagram

2.2. Principle for the main function module

The special metering integrated circuit (ASIC) integrated six load two order Σ - Δ type of A/D conversion, please take the digital signal processing measured by the voltage circuit as well as all the power, energy, effective values, power factor and frequency. This metering chip can measure the active power, reactive power, apparent power, active energy, reactive power, apparent energy of each phase and combined phase, and at the same time measuring current, voltage effective values, power factor, phase angle, frequency and other parameters, entirely satisfying the needs of power meter. The chip provides an SPI interface, convenient for metering parameters as well as parameter calibration between the management MCU.

3. Main Technical Performance & Parameters

3.1. limit of error caused by the current augment

Table 2 The limit value of the active percentage error of meters on balanced load

Meters for	Value of current	Power factor	Percentage error limits for meters of class		
			0.5S	Class 1	Class 2
Connection through current transformers	$0.01I_n \leq I < 0.05I_n$	1	± 1.0	± 1.5	± 2.0
	$0.05I_n \leq I \leq I_{max}$	1	± 0.5	± 1.0	± 1.2
	$0.02I_n \leq I < 0.1I_n$	0.5L、0.8C	± 1.0	± 1.5	± 2.0
	$0.1I_n \leq I \leq I_{max}$	0.5L、0.8C	± 1.0	± 1.0	± 1.2

DTSU666 series and DSSU666 series three phase electronic energy meter(DIN-Rail)	ZTY0.464.1002
Operation manual	Page 4, Total 18

Direct connection	$0.05I_b \leq I < 0.1I_b$	1	-	± 1.5	± 2.0
	$0.1I_b \leq I \leq I_{max}$	1	-	± 1.0	± 1.2
	$0.01I_b \leq I < 0.2I_b$	0.5L、0.8C	-	± 1.5	± 2.0
	$0.2I_b \leq I \leq I_{max}$	0.5L、0.8C	-	± 1.0	± 1.2
Note	In: secondary rated current of the current transformer; I_b : calibrated current of the meter; L: inductive; C: capacitive;				

Table 3 The limit value of the reactive percentage error of meters on balanced load

Value of current		$\sin\phi$ (inductive or capacitive)	Percentage error limits for meters of class	
Direct connection	Connection through current transformers		Class 2	
$0.05I_b \leq I < 0.1I_b$	$0.02I_n \leq I < 0.05I_n$	1	± 2.5	
$0.1I_b \leq I \leq I_{max}$	$0.05I_n \leq I \leq I_{max}$	1	± 2.0	
$0.1I_b \leq I < 0.2I_b$	$0.05I_n \leq I < 0.1I_n$	0.5	± 2.5	
$0.2I_b \leq I \leq I_{max}$	$0.1I_n \leq I \leq I_{max}$	0.5	± 2.0	
$0.2I_b \leq I \leq I_{max}$	$0.1I_n \leq I \leq I_{max}$	0.25	± 2.5	

Table 4 The limit value of the reactive percentage error of meters on balanced load

Value of current		Power factor	Percentage error limits for meters of class		
Direct connection	Connection through		0.5S	Class 1	Class 2
$0.1 I_b \leq I \leq I_{max}$	$0.05I_n \leq I \leq I_{max}$	1	± 0.6	± 2.0	± 3.0
$0.2I_b \leq I \leq I_{max}$	$0.1I_n \leq I \leq I_{max}$	0.5L	± 1.0	± 2.0	± 3.0

Table 5 The limit value of the reactive percentage error of meters on imbalanced load

Value of current		Power factor	Percentage error limits for meters of class	
Direct connection	Direct connection		Class 2	
$0.1 I_b \leq I \leq I_{max}$	$0.05I_n \leq I \leq I_{max}$	1	± 3.0	
$0.2I_b \leq I \leq I_{max}$	$0.1I_n \leq I \leq I_{max}$	0.5	± 3.0	

3.1. Starting and no-load condition

3.1.1. Starting

DTSU666 series and DSSU666 series three phase electronic energy meter(DIN-Rail)	ZTY0.464.1002
Operation manual	Page 5, Total 18

Under the power factor of 1.0 and started current, the instrument can be started and continuously measure (for multiple phase instrument, it will bring balanced load). If the instrument is designed based on measurement for dual directional energy, then it is applicable for each direction of energy.

Table 6 start current

Meters for	Class of meter			Power factor
	0.5S	1	2	
Direct connection	-	$0.004I_b$	$0.005I_b$	1
Connection through current transformers	$0.001I_b$	$0.002I_b$	$0.003I_b$	1

3.1.2. Test of no-load condition

When the voltage is applied with no current flowing in the current circuit, the test output of the meter shall not produce more than one pulse.

For this test, the current circuit shall be open-circuit and a voltage of 115 % of the reference voltage shall be applied to the voltage circuits.

The minimum test period Δt shall be

$$\Delta t \geq \frac{600 \times 10^6}{k \cdot m \cdot U_n \cdot I_{\max}} [\text{min}] \text{ for meters of class 0.5S or 1}$$

$$\Delta t \geq \frac{480 \times 10^6}{k \cdot m \cdot U_n \cdot I_{\max}} [\text{min}] \text{ for meters of class 2}$$

k is the number of pulses emitted by the output device of the meter per kilovarhour(imp/kvar·h);

m is the number of measuring elements;

U_n is the reference voltage in volts;

I_{\max} is the maximum current in amperes.

3.2. Electrical parameters

Table 7 Electrical parameters

Regulated operating voltage range	$0.9U_n \sim 1.1U_n$	
Extended operating voltage range	$0.7U_n \sim 1.3U_n$	
Power consumption of voltage	$\leq 1.5W \ \& \ 6VA$	
Power consumption of current	$I_b < 10A$	$\leq 0.2VA$
	$I_b \geq 10A$	$\leq 0.4VA$
Data storage time after pwer interruption	$\geq 10 \text{ years}$	

DTSU666 series and DSSU666 series three phase electronic energy meter(DIN-Rail)	ZTY0.464.1002
Operation manual	Page 6, Total 18

4. Main function

4.1. Displayed function

From the displayed interface, the electrical parameter and energy data are all primary side data (that is, the multiplied by current and voltage ratios). The energy measuring value will be displayed seven bits, with the displaying range from 0.00kWh to 9999999MWh.

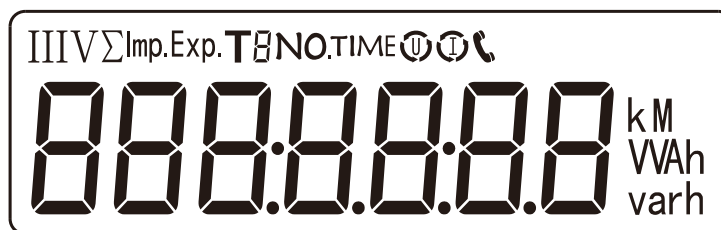









Figure 2 display

Table 8 Display interface

No.	Display interface	Instruction	No.	Display interface	Instruction
1		Positive active energy =10000.00kWh	10		Phase C current =5.002A
2		Reserve active energy =2345.67kWh	11		Combined phase active power =3.291kW
3		Protocol: MdoBus-RTU; address =001 Baudrate=9600 None parity, 2 stop bits	12		Phase A active power =1.090kW
4			13		Phase B active power =1.101kW
5		Phase A voltage =220.0V	14		Phase C active power =1.100kW

DTSU666 series and DSSU666 series three phase electronic energy meter(DIN-Rail)	ZTY0.464.1002
Operation manual	Page 7, Total 18

6		Phase B voltage =220.1V	15		Combined phase power factor PFt=0.500
7		Phase C voltage =220.20V	16		phase A power factor PFt=1.000
8		Phase A current =5.001A	17		Phase B power factor PFt=1.000
9		Phase B current =5.001A	18		phase A power factor PFt=-0.500

4.2. Programming function

4.2.1. Programming function

Table 9 Programming Parameter

Parameter	Value range	Description
C_t	1~9999	Current ratio, used for setting the input loop current ratio: When the current is connected to the line via the transformer, C_t =the rated current of the primary loop / the rated current of the secondary circuit; When the current is directly connected to the line, C_t shall be set as 1.
P_t	0.1~999.9	Voltage ratio, used for setting the voltage ratio of the input loop; When the voltage is connected to the line via the transformer, P_t = the rated voltage of the primary loop / the rated voltage of the secondary circuit; When the voltage is directly connected to the line, P_t shall be set as 1.0.
P_{rot}	1: 645;	Settings for communication stop bit and Parity bits:

DTSU666 series and DSSU666 series three phase electronic energy meter(DIN-Rail)	ZTY0.464.1002
Operation manual	Page 8, Total 18

	2: n.2; 3: n.1; 4: E.1; 5: O.1;	1: 645 mode; 2: None parity, 2 stop bits, n.2; 3: None parity, 1 stop bit, n.1; 4: Even parity, 1 stop bit, E.1; 5: Odd parity, 1 stop bit, O.1;
<i>bAud</i>	0: 1.200; 1: 2.400; 2: 4.800; 3: 9.600	Communication baud rate: (0:1200;1:2400;2:4800;3:9600;4:19200)
<i>Addr</i>	1~247	Communication address
<i>nEt</i>	0: n.34; 1: n.33;	Option for wiring mode: 0: n.34 represents three phase four wire; 1: n.33 represents three phase three wire.
<i>CLrE</i>	0:no; 1:E	The setting is 1, representing the allowed instrument energy data clearance, which will be zero reset after clearing.
<i>PLuS</i>	0:P; 1:Q; 2:S;	Pulse output: 0: active energy pulse; 1: reactive energy pulse; 2: Others.
<i>dISP</i>	0~30	Display in turns(second) 0: Timely display; 1~30: Time interval of actual display.
<i>bLcd</i>	0~30	Backlight lighting time control (minutes) 0: Normally light; 1~30: backlight lighting time without button operation

4.2.2. Programming operation

Button description: “SET” button represents “confirmation”, or “cursor shift” (when input digits), “ESC” button represents “exit”, “→” (“ ”) button represents “add”. The input code is (default 701).

DTSU666 series and DSSU666 series three phase electronic energy meter(DIN-Rail)	ZTY0.464.1002
Operation manual	Page 10, Total 18

Factory default communication parameters is DL/T 645-2007 protocol, the default baud rate is 2400bps, with the calibration bit and stop bit to be E.1 and instrument address (please see instrument factory number or crystal display screen).

Customized communication parameter is ModBus-RTU protocol, the baud rate is 9600bps, with the calibration bit and stop bit to be n.1, and the instrument address to be 1. The following table is the common ModBus protocol address table, can be asked for specified communication protocol by calling. ModBus_RTU protocol read command is 03H, write command is 10H.

Table 10 ModBus protocol address table

Parameter address	Parameter code	Instructions of parameters	Data type	Data length Word	R/W property
Keyboard parameters (specific parameters see the instructions of programming parameters, the actual value with (*) parameter = communication parameter value × 0.1)					
0000H	REV.	Version No.	16 bit with signal	1	R/W
0001H	UCode	Programming code codeE(1~9999)	16 bit with signal	1	R/W
0002H	ClrE	Power reset CLr.E(1:energy clear)	16 bit with signal	1	R/W
0003H	net	Network selection (0:three phase four wire,1:three phase three wire)	16 bit with signal	1	R/W
0006H	<i>I r A t</i>	Current transformer rate IrAt(1~9999)	16 bit with signal	1	R/W
0007H	<i>U r A t</i>	Voltage transformer rate UrAt (*) (1~9999 represents voltage ratio 0.1~999.9)	16 bit with signal	1	R/W
000AH	Disp	Rotating display time (s)	16 bit with signal	1	R/W
000BH	B.LCD	Backlight time control (s)	16 bit with signal	1	R/W
000CH	Endian	Single-precision floating point size end mode (0:ABCD;1:CDAB;2:BADC;3:DCBA;)	16 bit with signal	1	R/W
002CH	Protocol	Protocol switching (1:DL/T645-2007;2:n.2;3:n.1;4:E.1;5:o.1)	16 bit with signal	1	R/W
002DH	<i>b A u d</i>	Communication baud rate bAud (0:1200;1:2400;2:4800;3:9600;4:19200)	16 bit with signal	1	R/W
002EH	<i>A d d r</i>	Communication address Addr(1~247)	16 bit with signal	1	R/W

DTSU666 series and DSSU666 series three phase electronic energy meter(DIN-Rail)	ZTY0.464.1002
Operation manual	Page 11, Total 18

Electricity data on the secondary side					
2000H	Uab	Three phase line voltage data, Unit V($\times 0.1V$)	Single-precision floating point	2	R
2002H	Ubc		Single-precision floating point	2	R
2004H	Uca		Single-precision floating point	2	R
2006H	Ua	Three phase phase voltage data, Unit V V($\times 0.1V$) (Invalid for three phase three phase)	Single-precision floating point	2	R
2008H	Ub		Single-precision floating point	2	R
200AH	Uc		Single-precision floating point	2	R
200CH	Ia	Three phase current data, Unit A($\times 0.001A$)	Single-precision floating point	2	R
200EH	Ib		Single-precision floating point	2	R
2010H	Ic		Single-precision floating point	2	R
2012H	Pt	Combined active power, Unit W($\times 0.1W$)	Single-precision floating point	2	R
2014H	Pa	A phase active power, Unit W($\times 0.1W$)	Single-precision floating point	2	R
2016H	Pb	B phase active power, Unit W($\times 0.1W$) (Invalid for three phase three phase)	Single-precision floating point	2	R
2018H	Pc	C phase active power, Unit W($\times 0.1W$)	Single-precision floating point	2	R
201AH	Qt	Combined reactive power, Unit var($\times 0.1var$)	Single-precision floating point	2	R
201CH	Qa	A phase reactive power, Unit var($\times 0.1var$)	Single-precision floating point	2	R
201EH	Qb	B phase reactive power, Unit var($\times 0.1var$) (Invalid for three phase three phase)	Single-precision floating point	2	R
2020H	Qc	C phase reactive power, Unit var($\times 0.1var$)	Single-precision floating point	2	R
202AH	PFt	Combined power factor(positive number: inductive, negative number: capacitive) ($\times 0.001$)	Single-precision floating point	2	R
202CH	PFa	A phase power factor(positive number: inductive, negative number: capacitive) (Invalid for three phase three phase) ($\times 0.001$)	Single-precision floating point	2	R

DTSU666 series and DSSU666 series three phase electronic energy meter(DIN-Rail)	ZTY0.464.1002
Operation manual	Page 12, Total 18

202EH	PFb	B phase power factor(positive number: inductive, negative number: capacitive) (Invalid for three phase three phase) ($\times 0.001$)	Single-precision floating point	2	R
2030H	PFc	C phase power factor(positive number: inductive, negative number: capacitive) (Invalid for three phase three phase) ($\times 0.001$)	Single-precision floating point	2	R
2044H	Freq	Frequency, Unit Hz($\times 0.01$ Hz)	Single-precision floating point	2	R
Power secondary side data					
101EH	ImpEp	(current) positive total active energy	Single-precision floating point	2	R
1028H	ExpEp	(current) negative total active energy	Single-precision floating point	2	R
1032H	Q1Eq	(current) Total reactive energy of the first quadrant	Single-precision floating point	2	R
103CH	Q2Eq	(current) Total reactive energy of the second quadrant	Single-precision floating point	2	R
1046H	Q3Eq	(current) Total reactive energy of the third quadrant	Single-precision floating point	2	R
1050H	Q4Eq	(current) Total reactive energy of the fourth quadrant	Single-precision floating point	2	R

Note 1: When the ratio of the voltage transformer is 1, the data of read voltage transformer ratio register UrAt is 10. When the ratio of voltage transformer is 1, ignore the above table($UrAt \times 0.1$).

Note : Single-precision floating point adopts standard IEEE754 format, total 32 bit(4 word). The single-precision floating point mode is assumed to be 0, ABCD(high type in the front, low byte behind).

4.4. 3.4. Energy measurement function

The horizontal axis of the measurement plane represents the current vector I (fixed on the horizontal axis), and the instantaneous voltage vector is used to represent the current power transmission. Compared with the current vector I, it has phase angle φ .

The counter-clockwise direction φ angle is positive. A schematic diagram of the four-quadrant is shown in Figure 2.

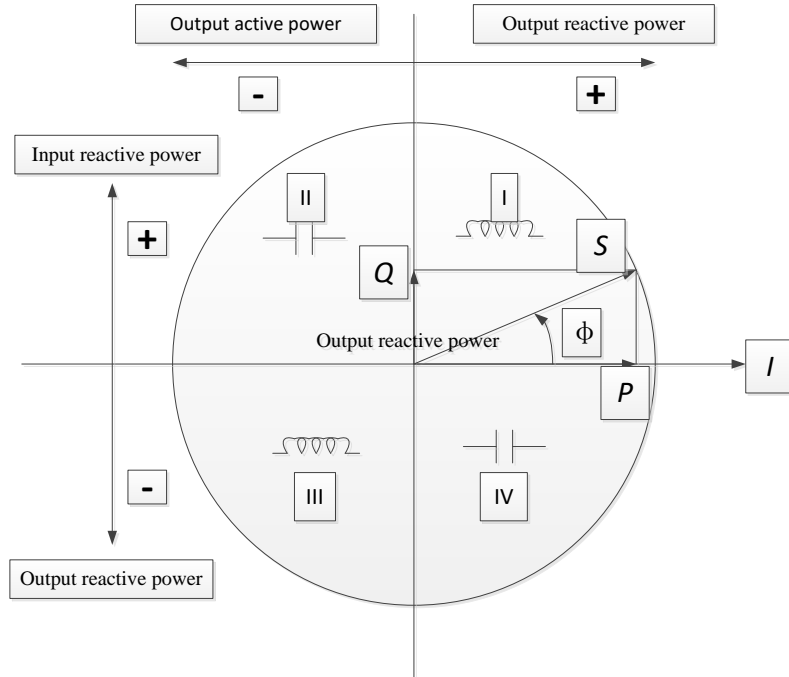

Figure 5 Measurement schematic diagram for energy four quadrants

5. Outline and installation size

Table 11 Installation size

Model	modulus	Outline size (length× width× height) mm	Installation size (din rail)
DTSU666	4	100×72×65	DIN35 din rail
DSSU666	4		

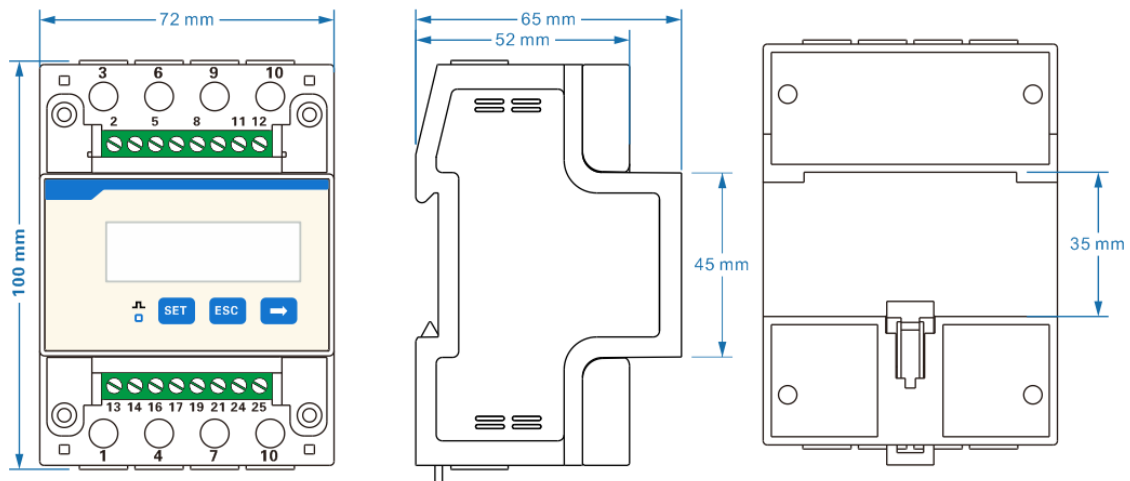

Figure 6 Outline size diagram

DTSU666 series and DSSU666 series three phase electronic energy meter(DIN-Rail)	ZTY0.464.1002
Operation manual	Page 14, Total 18

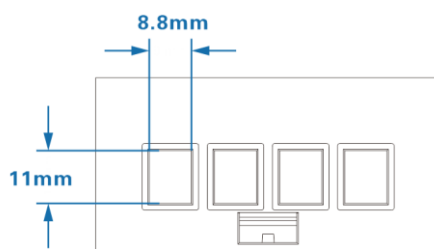

Figure 7 current cable terminal (Conductor Cross-sectional Area Range $\leq 16 \text{ mm}^2$)

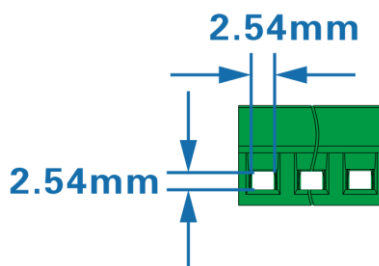

Figure 8 RS485 cable terminal (Conductor Cross-sectional Area Range $0.25\text{-}1\text{mm}^2$)

6. Installation and operation manual

6.1. Inspection Tips

When unpacking the carton, if the shell has obvious signs caused by severe impact or falling, please contact with the supplier as soon as possible.

After the instrument being removed from the packing box, it should be placed on a flat and safe plane, facing up, not overlaying for more than five layers. If not installed or used in a short time, the electric meter shall be packed and placed to the original packing box for storage.

6.2. Installation and tips

6.2.1. Installation and Inspection

If the model No or configuration in the original packing box is not in accordance with the requirement, please contact with the supplier. While, if the inner package or shell has been damaged after removing the instrument from the packing box, please do not install, power on the instrument, please contact with the supplier as soon as possible, instead.

6.2.2. Installation

DTSU666 series and DSSU666 series three phase electronic energy meter(DIN-Rail)	ZTY0.464.1002
Operation manual	Page 15, Total 18

It requires experienced electrician or professional personnel to install it and you must read this operation manual. During the installation, if the shell has obvious damage or marks caused by violent impact or falling, please do not install it or power on and contact with the supplier as soon as possible.

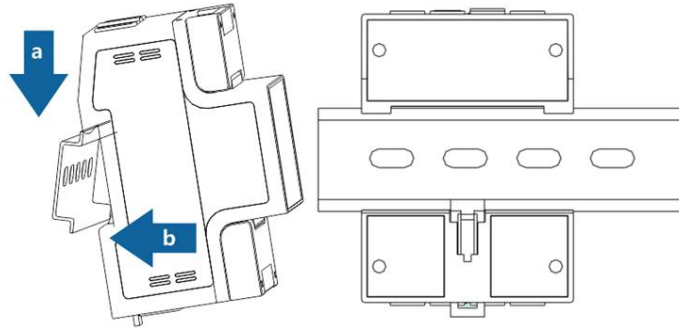

Figure 5

6.3. Typical wiring

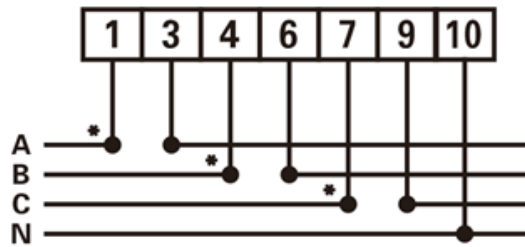

Figure 10 Three phase four wire: direct connect

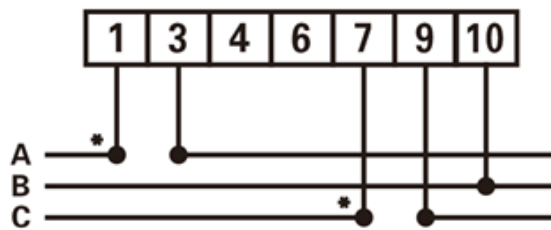

Figure 11 Three phase three wire: direct connect

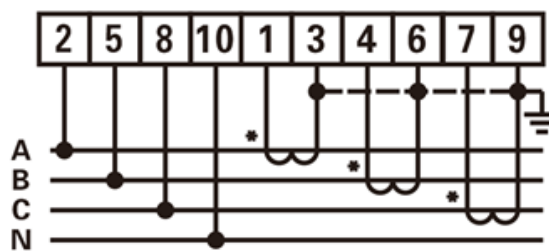

Figure 12 Three phase four wire: Connection through current transformers

DTSU666 series and DSSU666 series three phase electronic energy meter(DIN-Rail)	ZTY0.464.1002
Operation manual	Page 16, Total 18

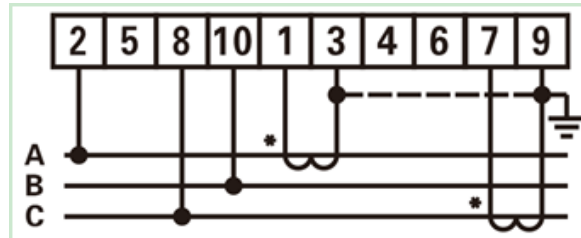

Figure 6 Three phase three wire: Connection through current transformers

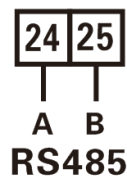

Figure 7 RS485



Figure 8 Pulse output

◆ Voltage signal (only for connection via current transformer)

2-----UA (Phase A voltage input terminal)

5 -----UB (Phase B voltage input terminal)

8-----UC (Phase C voltage input terminal)

11-----UN (Phase N voltage input terminal)

◆ Current signal:

1-----IA*(Phase A current input terminal)

3-----IA (Phase A current output terminal)

4-----IB*(Phase B current input terminal)

6-----IB (Phase B current output terminal)

7-----IC*(Phase C current input terminal)

9-----IC(Phase C current output terminal)

◆ RS485 Communication wire

24-----A (RS485 Terminal A)

15-----B (RS485 Terminal B)

◆ Auxiliary function

19----- Active energy and reactive energy output high terminal

21----- Active energy and reactive energy output low terminal

◆ Auxiliary function

19----- Active energy and reactive energy output high terminal

21----- Active energy and reactive energy output low terminal

DTSU666 series and DSSU666 series three phase electronic energy meter(DIN-Rail)	ZTY0.464.1002
Operation manual	Page 17, Total 18

7. Diagnosis, analysis and elimination for common faults

Fault phenomenon	Reason analysis	Elimination
No display when powered on	<ol style="list-style-type: none"> 1、 Incorrect wiring 2、 Abnormal voltage for the instrument 	<ol style="list-style-type: none"> 1. If it is wrongly connected, please reconnect based on the right wiring mode (see the wiring diagram). 2. If the supplied voltage is abnormal, please choose the specified voltage. 3. If not the above problems, please contact with the local supplier.
Abnormal RS485 communication	<ol style="list-style-type: none"> 1. RS485 communication cable is opened, short circuit or reversely connected. 2. Address, baud rate, data bit and check bit is not in accordance with the host computer. 3. The end of RS485 communication cable has not been matched with resistance (when the distance over than 100 meters) 4. Not matched with the communication protocol order of the host computer 	<ol style="list-style-type: none"> 1. If there is any problem with the communication cable, please change it. 2. Set the address, baud rate, data bit and check bit through buttons and confirm it is the same with the host computer, then set the operation to be “parameter settings”. 3. If the communication distance is over than 100 meters, and the communication parameter settings are the same as the host computer, but cannot be communicated, then please lower the baud rate or add a resistance of 120Ω at the start terminal and ending terminal.
Abnormal data for the electrical parameter (voltage, current, power, etc.)	<ol style="list-style-type: none"> 1. The transformer's ratio hasn't been set, and the instrument displays the 	<ol style="list-style-type: none"> 1. If setting the transformer ratio, please set the voltage ratio and current ratio based on

DTSU666 series and DSSU666 series three phase electronic energy meter(DIN-Rail)	ZTY0.464.1002
Operation manual	Page 18, Total 18

	secondary side data. 2. Wrong wiring.	“parameter setting” 2. If wrongly connected, please connect the voltage and current of phase A, B and C to the wiring terminal of the instrument.
Abnormal data for the electrical parameter read by communication (voltage, current, power, etc.)	1. Data read by communication is secondary side data, without transformer ratio. 2. Wrong analysis for data frame	1. Multiply the data read by communication with the voltage ratio and current ratio. 2. Analyze the data frame based on the format of the communication protocol, please pay attention to the mode of the big and small end of data.

8. Transportation & Storage

When transporting and unpacking the products, please confirm they are not severely impacted, transporting and storing based on Transportation, basic environmental conditions and testing methods for instrument and meters of JB/T9329-1999.

The instrument and accessories shall be stored in the dry and ventilated places, to avoid humidity and corrosive gas erosion, with the limited environmental temperature for storage to be $-40^{\circ}\text{C} \sim +70^{\circ}\text{C}$ and relative humidity not exceeding 85%.

9. Maintenance & Service

We guarantee free reparation and change for the multi-meter if found any unconformity with the standard, under circumstance of that the users fully comply with this instructions and complete seal after delivery within 18 months.

DTSU666 series and DSSU666 series three phase electronic energy meter(DIN-Rail)	ZTY0.464.1002
Operation manual	Page 19, Total 18

Dear clients,

Please assist us: when the product life is end, to protect our environment, please recycle the product or components, while for the materials that cannot be recycled, please also deal with it in a proper way. Really appreciate your cooperation and support.